



Solutions for
**WASTEWATER
TREATMENT**

 **Bonfiglioli**



We engineer dreams

Solutions for
WASTEWATER TREATMENT

CONTENTS

PRIMARY/PRE-TREATMENT	6
Water Gate.....	8
Trash Rake.....	9
Band Screener.....	10
Debris Filter.....	11
SECONDARY/WASTEWATER & SLUDGE TREATMENT	12
Clarifier.....	14
Screw Press.....	15
Aerator.....	16
COMPLETE SOLUTIONS FOR POWER TRANSMISSION & AUTOMATION	18
OUR STRIVING FOR THE FUTURE	20
OUR CONSTANT AMBITION	21
OUR GLOBAL PRESENCE	22

Engineering Solutions



WWW.BONFIGLIOLI.COM

WASTEWATER TREATMENT

EFFICIENT, COMPACT SOLUTIONS FOR WATER TREATMENT

From desalination to purification, water and wastewater is a complex sector that requires reliable solutions to ensure uninterrupted operation.

With a comprehensive portfolio of power transmission products, Bonfiglioli can offer efficient solutions for all kinds of applications to support wastewater treatment plants. Easy maintenance, adaptability, compactness and a wide torque range are other fundamental features demanded by water and wastewater processes.

Perfect control of the drive speed and therefore water flow, easy maintenance and high reliability are key elements that enable us to supply our customers with energy saving solutions for the filters, mixers, aerators, agitators, water flow control typically used in this sector.



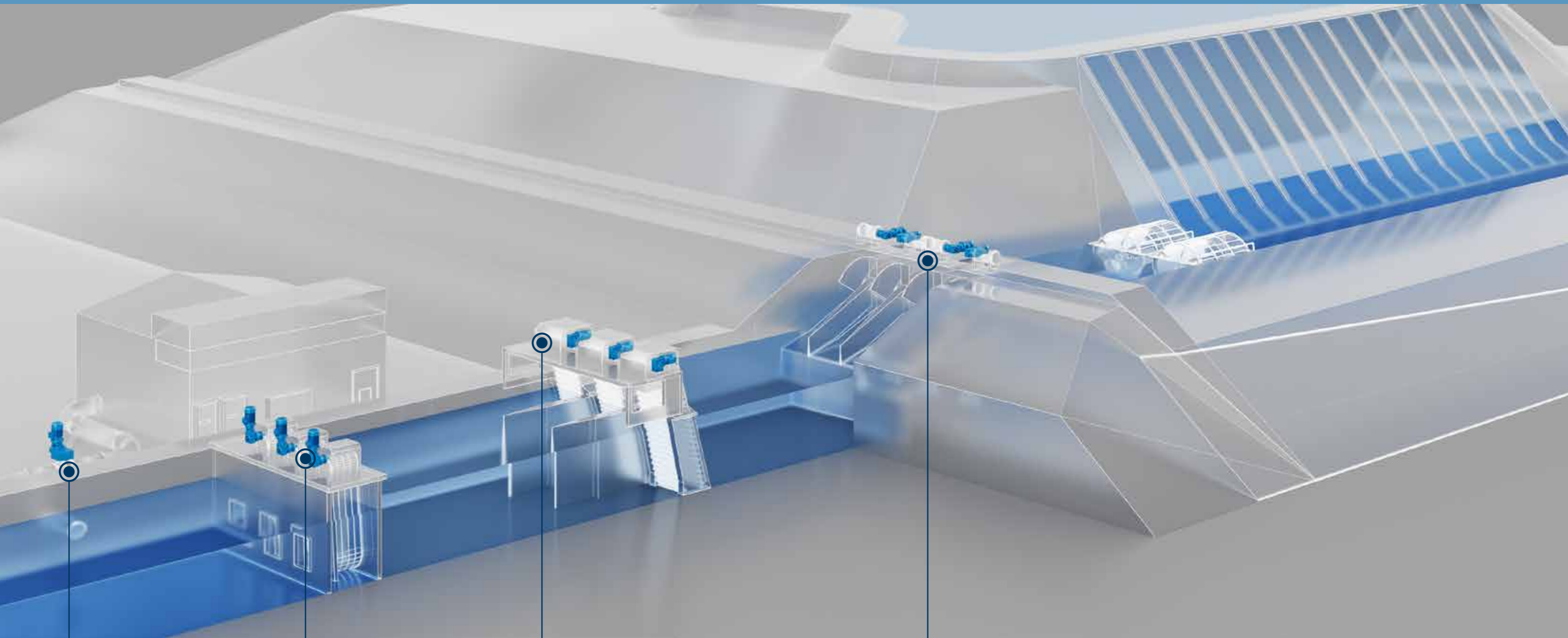

4 DEBRIS FILTER

3 BAND SCREENER

2 TRASH RAKE

1 WATER GATE

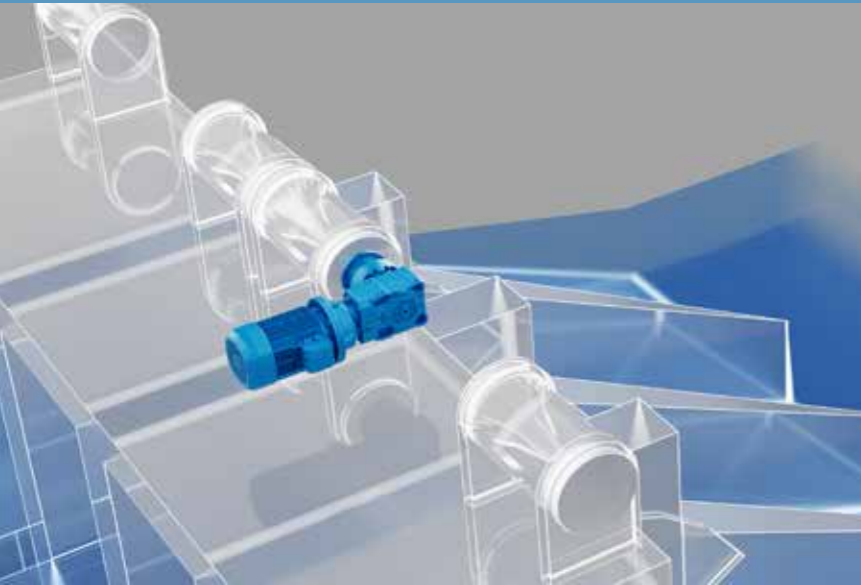

1
WATER GATE

Ensure precise and dependable flow control, even remotely. Our solution delivers top-tier control which is both reliable and efficient, leveraging a wide range of technologies for optimum performance even in challenging environmental conditions.

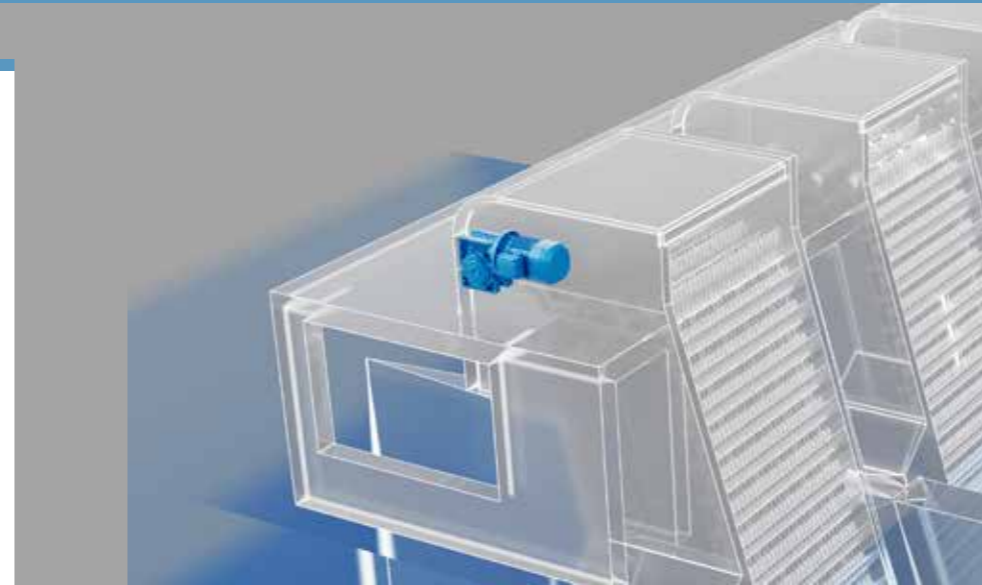

2
TRASH RAKE

Trash Rakes, together with similar machines, are engineered to efficiently extract debris, waste, and sizable materials from the primary water flow. Because of their critical function, durability and dependability are paramount with these machines. Our solutions offer unparalleled long operating lifetime, solidity, robustness and reliability. What's more, we seamlessly integrate rugged design with advanced technology for maintenance and preemptive servicing.

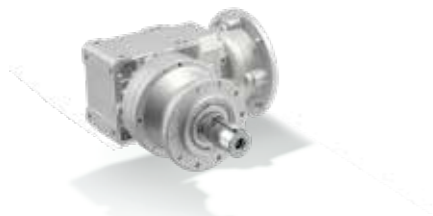

3/A Series

Combined planetary/helical bevel heavy duty gearbox



EVOX BXN Series

Asynchronous Induction Phase Motor



AxiaAgile Series

Advanced inverter



VF-W Series

Worm gearbox



EVOX BXN Series

Asynchronous Induction Phase Motor



AxiaAgile Series

Advanced inverter

BENEFITS

- High torque density & peak load capacity
- Modular and adaptable solution
- Low maintenance costs
- Minimized mounting space

- One motor for different markets
- Simplify installation complexities and inventory management
- Uncompromised Efficiency
- Modular electric motor

- Smooth start
- Variable "cut position" for smaller particles

BENEFITS

- Designed for enduring performance
- Reduced downtime by effectively absorbing peak loads
- Extreme mounting flexibility in compact installation space
- Easy maintenance

- One motor for different markets
- Simplify installation complexities and inventory management
- Uncompromised Efficiency
- Modular electric motor

- Smooth start
- Variable "cut position" for smaller particles

FEATURES

- High torque density & peak load capacity
- Modular and adaptable solution
- Low maintenance costs
- Minimized mounting space
- Fluoroelastomer and double lip seals

- IE3 Efficiency level
- Power range up to 7,5kW
- Built in DC brake
- Thermal protection
- Anti-condensate heaters
- Second shaft extension
- Anti corrosive painting up to C5M
- Tropicalization
- Degree of protection up to IP56

- CAN open support (variant depending)
- Industrial Ethernet support (variant depending)
- Sensorless control of synchronous, synchronous-reluctance and asynchronous motors
- DC link connection
- Integrated brake chopper
- Power failure control
- Programmable PI Controller
- Integrated PLC (variant depending)
- Master/slave function with electronic gear
- Integrated safe torque off STO (SIL 3 / PL e / Cat.3) function
- Intelligent current limits
- Output frequency 0...599 Hz, higher frequencies on request
- Diagnosis and setup via optional keypad and Service interface for PC connection

FEATURES

- Torque range: 13 to 7100Nm
- Ratio up to 1:10.000
- Wide option range including reinforced bearings, embedded torque limiter and torque arm
- Fluoroelastomer and double lip seals

- IE3 Efficiency level
- Power range up to 7,5kW
- Built in DC brake
- Thermal protection
- Anti-condensate heaters
- Second shaft extension
- Anti corrosive painting up to C5M
- Tropicalization
- Degree of protection up to IP56

- CAN open support (variant depending)
- Industrial Ethernet support (variant depending)
- Sensorless control of synchronous, synchronous-reluctance and asynchronous motors
- DC link connection
- Integrated brake chopper
- Power failure control
- Programmable PI Controller
- Integrated PLC (variant depending)
- Master/slave function with electronic gear
- Integrated safe torque off STO (SIL 3 / PL e / Cat.3) function
- Intelligent current limits
- Output frequency 0...599 Hz, higher frequencies on request
- Diagnosis and setup via optional keypad and Service interface for PC connection



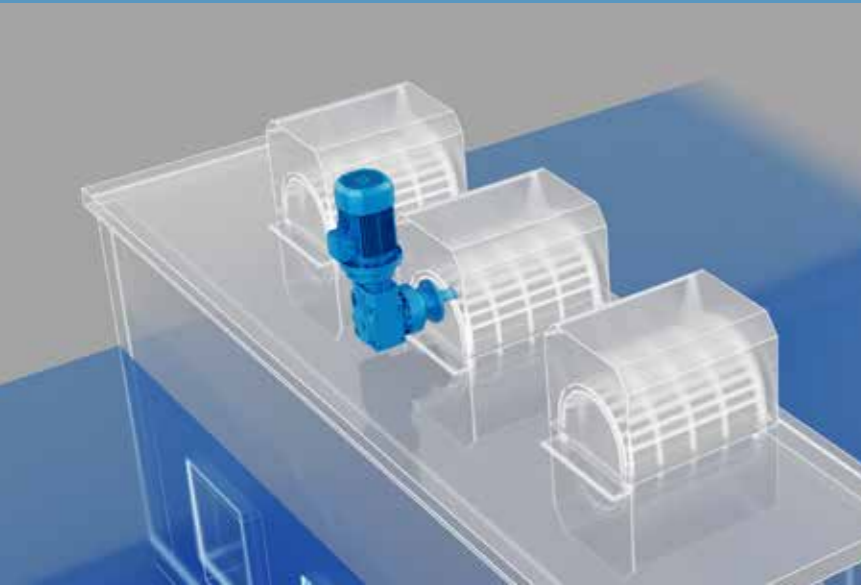

3

BAND SCREENER

Stormwater often carries a mix of natural and man-made debris, which all needs to be effectively separated from the water before it goes on to the next stage of purification. A range of movable cleaning systems are used to ensure the filters stay clear at all times. Our gearmotors and solutions stand out as the best choice, offering a blend of reliability, robustness, cost-effectiveness, and efficiency.

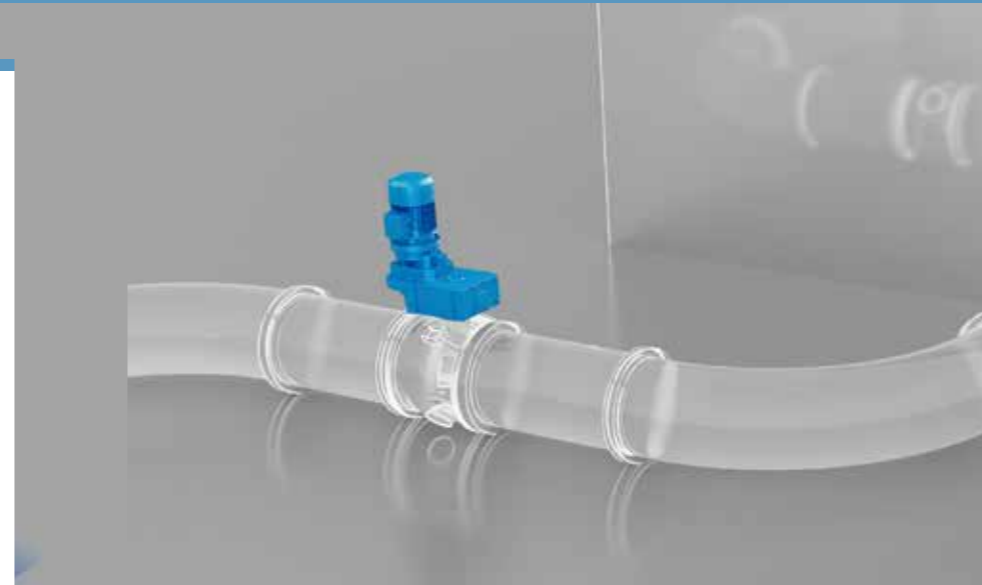

4

DEBRIS FILTER

Whether it's a Band Screener or a Rake Filter, the ultimate goal of the Debris Filter is to efficiently capture and eliminate unwanted materials and debris from the fluid stream, ensuring a clean flow for the subsequent treatment stages. Our solution boasts a solid, robust design precisely engineered to withstand demanding operation and harsh climates. What's more, it simplifies maintenance and servicing procedures, enhancing overall efficiency.

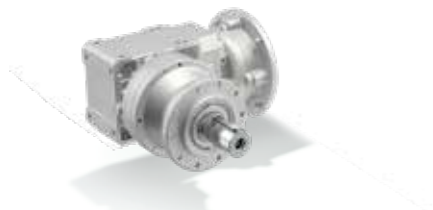

3/A Series

Combined planetary/helical bevel heavy duty gearbox



BX Series

Asynchronous induction phase motor



AxiaAgile Series

Advanced inverter



F Series

Shaft Mounted Gearbox



EVOX BXN Series

Asynchronous Induction Phase Motor



AxiaAgile Series

Advanced inverter

BENEFITS

- High torque density & peak load capacity
- Modular and adaptable solution
- Low maintenance costs
- Minimized mounting space

- Reliable, balanced and robust
- Compliant with the most of the efficiency standards

- Smooth start
- Variable "cut position" for smaller particles

BENEFITS

- High efficiency
- Reliability and robustness
- Compactness
- Low maintenance

- One motor for different markets
- Simplify installation complexities and inventory management
- Uncompromised Efficiency
- Modular electric motor

- Smooth start
- Variable "cut position" for smaller particles

FEATURES

- Backstop device
- Planetary and helical bevel gear technology
- Shaft mounting
- Rain Canopy
- Fluoroelastomer and double lip seals

- Power range up to 22kW
- Built in DC brakes
- Thermal protection
- Anti-condensate heaters
- Second shaft extension
- Anti corrosive painting up to C5M
- Tropicalization
- Degree of protection up to IP56

- CAN open support (variant depending)
- Industrial Ethernet support (variant depending)
- Sensorless control of synchronous, synchronous-reluctance and asynchronous motors
- DC link connection
- Integrated brake chopper
- Power failure control
- Programmable PI Controller
- Integrated PLC (variant-depending)
- Master/slave function with electronic gear
- Integrated safe torque off STO (SIL 3 / PL e / Cat.3) function
- Intelligent current limits
- Output frequency 0...599 Hz, higher frequencies on request
- Diagnosis and setup via optional keypad and Service interface for PC connection

FEATURES

- Shaft mounted solution with different output configurations
- Housing integrated torque arm design and anti-vibration kits
- Wide range of ratios
- Availability of different grade of protection
- Compact or IEC/NEMA flanged motor adaptors
- Fluoroelastomer and double lip seals

- IE3 Efficiency level
- Power range up to 7,5kW
- Built in DC brake
- Thermal protection
- Anti-condensate heaters
- Second shaft extension
- Anti corrosive painting up to C5M
- Tropicalization
- Degree of protection up to IP56

- CAN open support (variant depending)
- Industrial Ethernet support (variant depending)
- Sensorless control of synchronous, synchronous-reluctance and asynchronous motors
- DC link connection
- Integrated brake chopper
- Power failure control
- Programmable PI Controller
- Integrated PLC (variant-depending)
- Master/slave function with electronic gear
- Integrated safe torque off STO (SIL 3 / PL e / Cat.3) function
- Intelligent current limits
- Output frequency 0...599 Hz, higher frequencies on request
- Diagnosis and setup via optional keypad and Service interface for PC connection



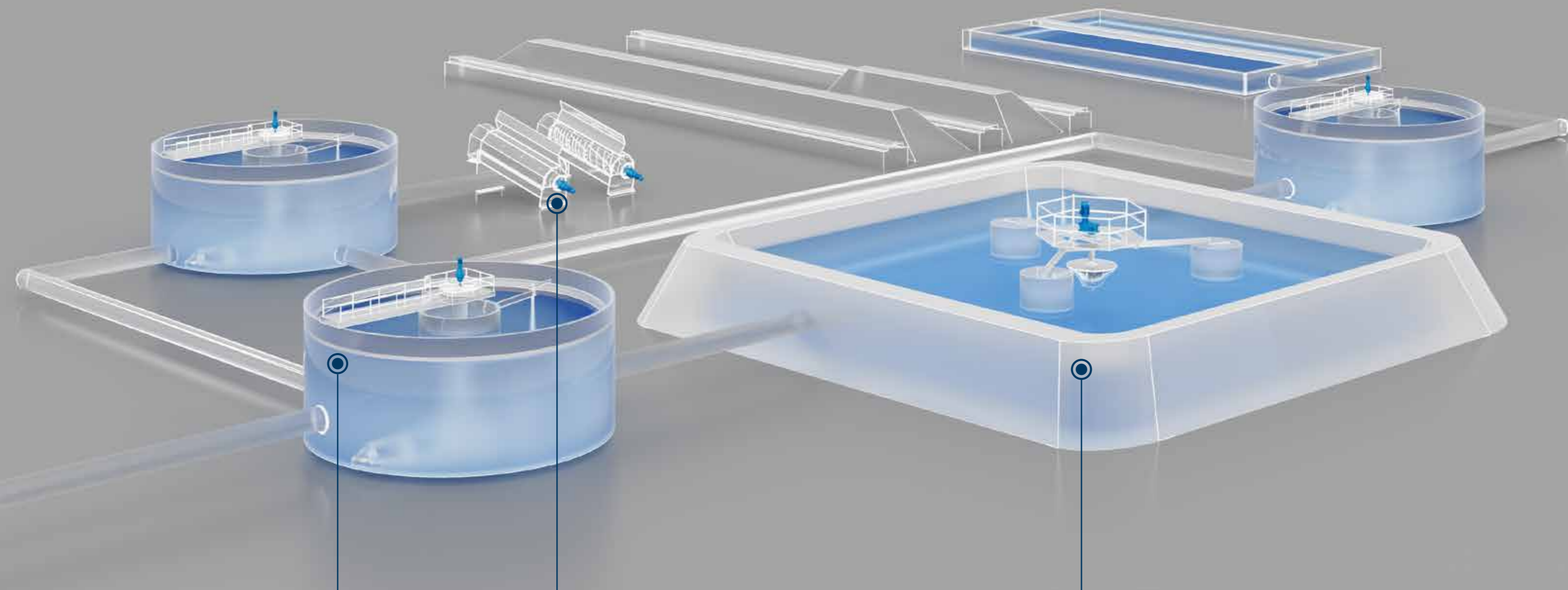

1 CLARIFIER

2 SCREW PRESS

3 AERATOR

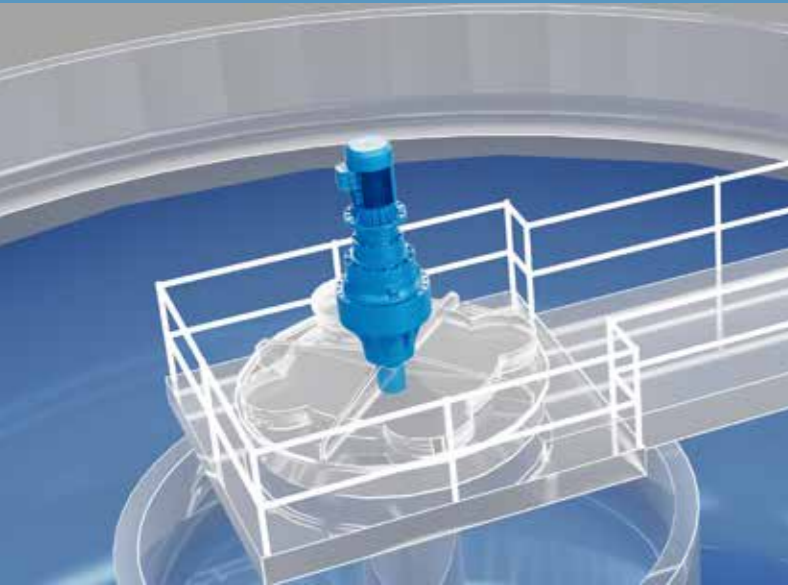

1
CLARIFIER

In the latter phase of treatment, water is clarified using various methods, like applying coagulants and flocculants to facilitate the aggregation of fine particles, settling tanks where gravity aids the separation of particles, or mechanical devices that physically remove impurities from the water. This stage typically demands an aggressive environment, high torque, and low speed. Our solution and products are meticulously crafted to meet the precise technical specifications of the clarifier. Torque control protects against system failures caused by blade overload, ensuring smooth operation.



2
SCREW PRESS

The process of separating liquid from solids usually involves pressing sludge or slurry, followed by the separation of water and solids. The pressing is often performed using a press with a rotating screw housed in a cylindrical or conical structure. As the screw rotates, it compresses the sludge, expelling water through press apertures while retaining the dewatered solids. This operation often means high specific axial loads have to be handled, which is why our extensive product range offers a variety of technologies and solutions to ensure robust, reliable performance. The modular design of the 300 M series aligns seamlessly with the required screw speed, promoting efficient operation.



300M Series
Planetary Gearbox



BX Series
Asynchronous induction phase motor



AxiaVert series
Premium drive



300M Series
Planetary Gearbox



BX Series
Asynchronous induction phase motor



Active Cube Series
Premium inverter

BENEFITS

- Robustness
- Reliability in harsh working conditions & wide range of temperature
- High torque density
- Modularity
- High overhung load capacity

- Reliable, balanced and robust
- Compliant with the most of the efficiency standards

- Multi-drive synchronization & torque control
- Drive Control is highly customizable
- Extremely compact

BENEFITS

- Robustness
- Reliability in harsh working conditions and wide range of temperature
- High torque density
- Modularity
- High overhung load capacity

- Reliable, balanced and robust
- Compliant with the most of the efficiency standards

- Multi-drive synchronization & torque control
- Drive Control is highly customizable
- Extremely compact

FEATURES

- Widest range of ratios
- Easy to fit output pinion
- IEC or NEMA motor flange
- Wide range of motion control solutions
- Availability of different grades of protection
- Fluoroelastomer and double lip seals

- Power range up to 22kW
- Built in DC brakes
- Thermal protection
- Anti-condensate heaters
- Second shaft extension
- Anti corrosive painting up to C5M
- Tropicalization
- Degree of protection up to IP56

- Power range: 0.25 to 15 kW (up to 200 kW in preparation)
- Electric shaft with master/slave configuration (Systembus)
- Master & slave control & communication protocol
- Optional integrated PLC (IEC61131)

FEATURES

- Widest range of ratios
- Easy to fit output pinion
- IEC or NEMA motor flange
- Wide range of motion control solutions
- Availability of different grades of protection
- Fluoroelastomer and double lip seals

- Power range up to 22kW
- Built in DC brakes
- Thermal protection
- Anti-condensate heaters
- Second shaft extension
- Anti corrosive painting up to C5M
- Tropicalization
- Degree of protection up to IP56

- Power range: 0.25 to 400 kW (parallel connection: up to 1200 kW)
- Electric shaft with master/slave configuration (Systembus)
- Master & slave control & communication protocol
- Integrated VPLC

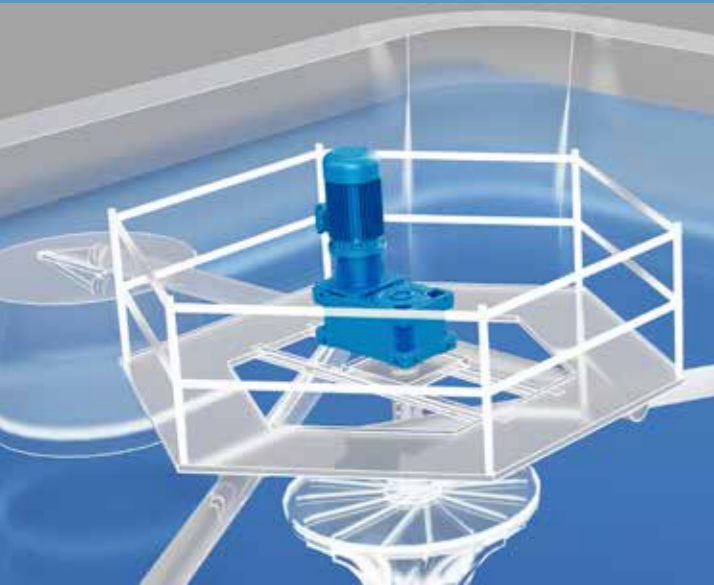

3

AERATOR

Aerator, mixer, and agitator devices are specifically engineered to introduce air or other gases into liquids, aiding processes like oxygenation or other chemical reactions. This is achieved through rotating systems, like paddle or shaft agitators, which generate fluid movement and produce bubbles.

Our products and solutions are meticulously designed to meet the rigorous demands of these applications. Their capabilities can withstand high radial loads, ensure mechanical separation between the lubrication chamber and output, regulate speed effectively, and thrive in aggressive atmospheres. Remote control and preventive maintenance solutions are available as extra options, ensuring seamless integration with the primary requirements for the application.



HDP Series

Heavy Duty Geared Motor
(Helical-Parallel)



BX Series

Asynchronous induction
phase motor



AxiaVert series

Premium drive

BENEFITS

- Robustness
- Reliability in harsh working conditions and wide range of temperature
- Space effective U-shape arrangement
- High overhung load capacity
- Tailored service and warranty plans
- Pre-sales and product definition support according to the material handling and lifting standards

- Reliable, balanced and robust
- Compliant with the most of the efficiency standards

- Multi-drive synchronization & torque control
- Drive Control is highly customizable
- Extremely compact

FEATURES

- Double input and output shaft
- Wide range of ratios
- Transmissible torque up to 210.000 Nm
- IEC or NEMA motor flange
- Safety solutions according to the customer requirements
- Wide range of motion control solutions
- Availability of different grade of protection

- Power range up to 22kW
- Built in DC brakes
- Thermal protection
- Anti-condensate heaters
- Second shaft extension
- Anti corrosive painting up to C5M
- Tropicalization
- Degree of protection up to IP56

- Power range: 0.25 to 15 kW (up to 200 kW in preparation)
- Electric shaft with master/slave configuration (Systembus)
- Master & slave control & communication protocol
- Optional integrated PLC (IEC61131)



GEAR UNITS

HEAVY DUTY Helical parallel shaft gear units HDP Series

- Torque range: 5,190 to 147,070 Nm
- Gear ratios: 7.1 to 500

Planetary gear units | 300M Series

- Torque range: 1,250 to 1,286,000 Nm
- Gear ratios: 3.4 ... 2,916

Combined planetary/helical bevel gear units 3/A Series

- Torque range: 46,660 to 1,188,610 Nm
- Gear ratios: 30 to 1,160

LIGHT DUTY Worm gear units | W-VF Series

- Torque range: 13 to 7,100 Nm
- Gear ratios: 5.6 to 10,000

Helical parallel gear units | F Series

- Torque range: 140 to 14,000 Nm
- Gear ratios: 6.4 to 2,188

ELECTRIC MOTORS

Asynchronous IEC motors | BN, BE, BX Series

Asynchronous compact motors | MN, ME, MX series

A complete range of AC motors, meeting worldwide MEPS (e.g. IE3)

- Power range: 0.06 to 355 kW
- Poles: 4



Asynchronous IEC motors | eVOX BXN Series

Asynchronous compact motors | eVOX MXN Series

A complete range of AC motors, meeting application worldwide MEPS (e.g. IE3)

- Power range: 0.12 to 7.5 kW
- Poles: 4



INVERTERS

HEAVY DUTY

Premium drive | AxiaVert series

- AXV20: 0.25 - 9.2 kW / 230 V 1- or 3-phase
- AXV40: 0.25 - 15 kW / 400 V 3-phase

Premium inverter | Active Cube Series

- ACU210: 0.25 - 9.2 kW / 1- or 3-phase 230 V
- ACU410*: 0.25 - 400 kW / 3-phase 380...480 V
- ACU510*: 160 - 400 kW / 3-phase 525 V
- ACU610*: 160 - 400 kW / 3-phase 690 V

LIGHT DUTY

Premium drive | AxiaVert series

- AXV20: 0.25 - 9.2 kW / 230 V 1- or 3-phase
- AXV40: 0.25 - 15 kW / 400 V 3-phase

Premium inverter | Active Cube Series

- ACU210: 0.25 - 9.2 kW / 1- or 3-phase 230 V
- ACU410*: 0.25 - 400 kW / 3-phase 380...480 V
- ACU510*: 160 - 400 kW / 3-phase 525 V
- ACU610*: 160 - 400 kW / 3-phase 690 V

Advanced inverter | Agile Series

- AXA20: 0.12 - 3 kW / 1-phase | 0.25 - 7.5 kW / 3-phase 230 V
- AXA40: 0.25 - 11 kW / 3-phase 380...480 V

* up to 1200 kW with parallel connection

OUR STRIVING FOR THE FUTURE

DESIGN SIMULATION

Bonfiglioli uses the most advanced **virtual simulation techniques** to accelerate the validation process. This reduces time to market and provides customers with optimized, efficient solutions.



TEST LABORATORIES

In our R&D department we **research, develop, validate and certify** all the products and solutions that are engineered and manufactured in our plants across the world.



CO-ENGINEERING

At Bonfiglioli **we work closely with our customers to satisfy all their needs** and requirements with a truly tailor-made solution.



OUR CONSTANT AMBITION

QUALITY, HEALTH, SAFETY, ENVIRONMENT & ENERGY

QUALITY: WE CARE ABOUT OUR CUSTOMERS

Our team is completely dedicated to continuous improvement in the areas of quality, safety, environmental and energy, throughout the entire value chain, from the smallest supplier to the end customer. Bonfiglioli is committed to achieving the highest quality standards, and our products are intended to generate value for our customers while respecting both people and the environment. We design, manufacture and supply effective products and services that set a benchmark for quality in the industry.

Bonfiglioli management systems are certified ISO 9001:2015, ISO 14001:2015, ISO 45001:2023 and ISO 50001:2018, while our products are covered by 7 international certifications. Responsibility, excellence and continuous improvement are the basic elements that make us the favored partner of our clients and suppliers.

HEALTH & SAFETY: SUSTAINABILITY STARTS WITH SAFETY

Prevention of accidents and incidents is a key element in our company's sustainability strategy and an integral part of every one of our business processes. Successful risk management is essential for protecting our employees and assets, thereby strengthening their contributions.

ENVIRONMENT & ENERGY: RESPECT THE PRESENT TO BUILD THE FUTURE

At Bonfiglioli, we believe that respect for the present and adopting environmental protection and energy efficiency policies are essential if we are to enjoy a better future.



OUR GLOBAL PRESENCE

Thanks to an international network of closely interconnected commercial and production sites, we can guarantee the same high standards of Bonfiglioli quality anywhere at any given time. We know that our direct presence in local markets is the key to long-lasting success, so our family includes 17 production sites, 23 commercial sites and more than 550 distributors around the world.

Our organization is always close by, offering complete and efficient solutions and supporting our customers with dedicated services, co-engineering and after-sales assistance.

17
PRODUCTION SITES

23
COMMERCIAL SITES

80
COUNTRIES

550
DISTRIBUTORS

~5,000
PEOPLE

AUSTRALIA

Bonfiglioli Transmission (Aust.) Pty Ltd
2, Cox Place Glendenning NSW 2761
Locked Bag 1000 Plumpton NSW 2761
Tel. +61 2 8811 8000



BRAZIL

Bonfiglioli Redutores do Brasil Ltda
Av. Osvaldo Fregonezi, 171, cjs 31 e 44
CEP 09851-015 - São Bernardo do Campo
São Paulo
Tel. +55 11 4344 2322



CHINA

Bonfiglioli Drives (Shanghai) Co. Ltd.
#68, Hui-Lian Road, QingPu District,
201707 Shanghai
Tel. +86 21 6700 2000



Selcom Electronics (Shanghai) Co., Ltd

A7, No.5399, Waiqingsong Road, QingPu
District,
201707 Shanghai
Tel. +86 21 6010 8100



A24, No.5399, Waiqingsong Road, QingPu
District,
201707 Shanghai
Tel. +86 21 6010 8100



FRANCE

Bonfiglioli Transmission S.A.S.
14 Rue Eugène Pottier
Zone Industrielle de Moimont II
95670 Marly la Ville
Tel. +33 1 34474510



GERMANY

Bonfiglioli Deutschland GmbH
Sperberweg 12 - 41468 Neuss
Tel. +49 0 2131 2988 0



Bonfiglioli Deutschland GmbH
Europark Fichtenhain B6 - 47807 Krefeld
Tel. +49 0 2151 8396 0



O&K Antriebstechnik GmbH
Ruhrallee 8-12 - 45525 Hattingen
Tel. +49 0 2324 2050 1



INDIA

Bonfiglioli Transmission Ltd.
Mobility & Wind Industries
AC 7 - 11, SIDCO Industrial Estate,
Thirumudivakkam
Kancheepuram - 600132 - Tamil Nadu
Tel. +91 844 844 8649



Industry & Automation Solutions
Survey No. 528/1, Perambakkam High Road
Mannur Village, Sriperumbudur Taluk
Kancheepuram - 602 105 - Tamil Nadu
Tel. +91 844 844 8649



Industry & Automation Solutions

Plot No E-5/2, Badhalwadi
Talegaon MIDC Phase II,
Pune - 410 507 - Maharashtra
Tel. +91 844 844 8649



ITALY

Bonfiglioli Riduttori S.p.A.
Industry & Automation Solutions
Via Cav. Clementino Bonfiglioli, 1
40012 Calderara di Reno
Tel. +39 051 6473111



Industry & Automation Solutions
Via Sandro Pertini, lotto 7b
20080 Carpiano
Tel. +39 02985081



Mobility & Wind Industries
Via Enrico Mattei, 12 Z.I. Villa Selva
47122 Forlì
Tel. +39 0543 789111



Industry & Automation Solutions
Via Unione, 49 - 38068 Rovereto
Tel. +39 0464 443435/36



Selcom Group S.p.A.
Via Achille Grandi, 5
40013 Castel Maggiore (BO)
Tel. +39 051 6387111



Via Marino Serenari, 18
40013 Castel Maggiore (BO)
Tel. +39 051 6387111



Via Cadriano, 19
40057 Cadriano (BO)
Tel. +39 051 6387111



NEW ZEALAND

Bonfiglioli Transmission (Aust.) Pty Ltd
88 Hastie Avenue, Mangere Bridge,
2022 Auckland
PO Box 11795, Ellerslie
Tel. +64 09 634 6441



SINGAPORE

Bonfiglioli South East Asia Pte Ltd
8 Boon Lay Way, #04-09,
8@ Tadehub 21, Singapore 609964
Tel. +65 6268 9869



SLOVAKIA

Bonfiglioli Slovakia s.r.o.
Robotnícka 2129
Považská Bystrica, 01701 Slovakia
Tel. +421 42 430 75 64



SOUTH AFRICA

Bonfiglioli South Africa Pty Ltd.
55 Galaxy Avenue, Linbro Business Park,
Sandton, Johannesburg
2090 South Africa
Tel. +27 11 608 2030



SPAIN

Tecnotrans Bonfiglioli S.A
Avinguda del Ferrocarril, n° 14,
Polígono Industrial Can Estapè
08755 Castellbisbal - Barcelona
Tel. +34 93 447 84 00



TURKEY

Bonfiglioli Türkiye Jsc
Atatürk Organize Sanayi Bölgesi,
10007 Sk. No. 30
Atatürk Organize Sanayi Bölgesi,
35620 Çiğli - İzmir
Tel. +90 0 232 328 22 77



UNITED KINGDOM

Bonfiglioli UK Ltd.
Unit 1 Calver Quay, Calver Road, Winwick
Warrington, Cheshire - WA2 8UD
Tel. +44 1925 852667



USA

Bonfiglioli USA Inc.
3541 Hargrave Drive
Hebron, Kentucky 41048
Tel. +1 859 334 3333



VIETNAM

Bonfiglioli Vietnam Co. Ltd.
Lot C-9D-CN, My Phuoc 3 Industrial Park,
Thoi Hoa ward, Ben Cat city, Binh Duong
province, Vietnam
Tel. +84 274 3577411





We have a relentless commitment to excellence, innovation & sustainability. Our team creates, distributes and services world-class power transmission & drive solutions to keep the world in motion.

HEADQUARTERS

Bonfiglioli S.p.A

Via Cav. Clementino Bonfiglioli, 1
40012 Calderara di Reno - Bologna (Italy)
Tel. +39 051 6473111

